

CAUTION

Damaged lenses or UV safety screens MUST be replaced before luminaire is used.

(a) the product should be inspected and any faults corrected when replacing or adjusting a lamp, with particular attention to all internal and external wiring,

(b) At least once every twelve months the product, if portable, should be bench inspected for electrical and mechanical wear and damage. If not portable this inspection should be carried out in situ.

(c) Depending upon usage, internal and external wiring will deteriorate in time and should be replaced at the first indication of wear or aging.

(d) Product can be returned to any CCT service representative for repair and or maintenance. Spare and replacement parts can be supplied for use by other competent service technicians available to the user.

Finally ...

**CHECK CABLE AND PLUG FOR ANY SIGNS OF DAMAGE
REPLACE DAMAGED PARTS IMMEDIATELY.**

CCT Theatre Lighting Limited, is constantly developing, improving and changing its product line. All descriptions and specifications in this publication present only general particulars and shall not form any part of any contract. The right is reserved to change the specification without prior notification.

ACCESSORIES

Z0014 Extra colour frame.

Z0081 4 leaf rotatable barn door.

Y0083 Hook clamp

Y0085 Safety chain

GENERAL USER INFORMATION

CCT products, unless specifically stated otherwise, are intended for lighting purposes only.

Follow the information given on the specific product information sheet. The Company will not accept responsibility for any injury, damage or loss which may arise as a result of incorrect operation or maintenance. Ensure that the rated voltage of the luminaire is compatible with the mains supply to be used.

Installation should be carried out in accordance with local wiring regulations (e.g. in the U.K. these are the "Regulations for Electrical Installation" published by the Institution of Electrical Engineers).

The electricity supply should be switched off before any electrical work is undertaken including maintenance, replacing a fuse or lamp.

Unless otherwise marked on the luminaire, all CCT luminaires are designed for operation in a maximum ambient temperature of 45°C for indoor use.

Unless otherwise marked on the luminaire, all CCT luminaires are for use in normal indoor conditions (IP20).

Luminaires should not be used in damp, dusty or corrosive situations. Observe the correct polarity when making connections to the mains.

supply and follow all specific wiring instructions. Observe mounting limits imposed by mounting surface material.

Observe temperature limits imposed by mounting surface material. Follow specific CCT lamp instructions as well as those of the lamp manufacturer. Observe luminaire maximum wattage limitations.

The lamp holders used in CCT luminaires are not designed to receive "life adaptors" or similar devices. The Company can accept no liability for the installation or use of such devices or for any loss or damage whatsoever,

nor for any death or personal injury which may arise in consequence of the installation or use of any such devices within CCT luminaires.

CCT luminaires must not be covered by heat insulating material or by any other material which prevents proper heat dissipation.

Luminaire enclosures must not be opened immediately after switching off and adequate time must be allowed for lamps, ballasts, etc., to cool.

Observe carefully the limitation on the minimum distance from the lighting surface or object.

Failed lamps should be replaced promptly and the luminaire should be switched off as soon as lamp failure is noted to avoid damage.

Only replacement components authorised by CCT may be used. Unless otherwise stated CCT luminaires are designed for direct connection to a standard mains supply as marked on the luminaire.

Servicing, e.g. cleaning, Lamp or fuse replacement, etc., should only be carried out after luminaire has been made electrically safe.

Cleaning should be carried out at regular intervals for hygienic reasons and to ensure that dirt does not accumulate to an extent that will impair the electrical and or thermal safety of the luminaire or product. Regular cleaning will also ensure that the optical performance is maintained.

CCT lighting

USER INFORMATION

Leaflet Ref: W0080

Jan '90

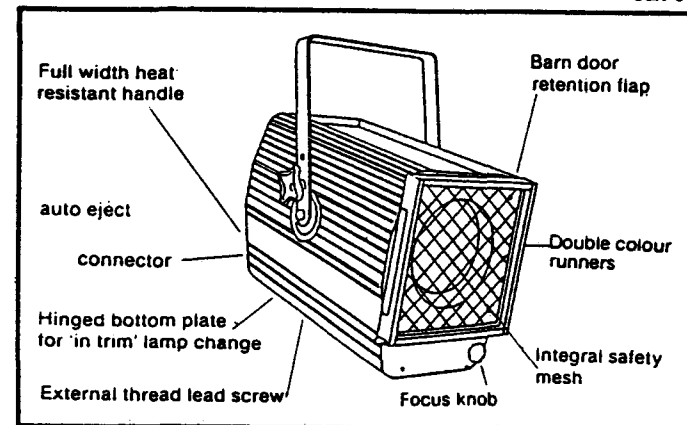

Starlette Fresnel

7° - 50° 2000W

Order Code Z0080

WARNING - BEFORE USE :-

- Read CCT Lighting General User Information
- Read these instructions.
- Inspect product for damage upon removal from its carton.
- Ensure that external supply wiring and socket (if to be used) is properly installed and protected.

THIS INFORMATION IS GIVEN IN THE BEST INTERESTS OF:
Safety, Handling, Installation, Use and Maintenance of products sold by CCT lighting.

Instructions relevant to each product will be found in the carton in which the product is supplied. They must be carefully read before any attempt is made to use and/or install the product. The instruction sheet should be retained for further reference. Additional copies are available on request.

In the UK, installers and users are obliged under the "Health and Safety at Work Act" to ensure that they are acquainted with information supplied with the product and are fully aware of any precautions that need to be taken.

CCT products are designed to conform to the requirements of UK law and to the requirements of relevant national and international standards.

CCT LIGHTING (UK) LTD
UNIT 3 ELLESMERE BUSINESS PARK
HAYDN ROAD
NOTTINGHAM
NG5 1DX
TEL: 44 (0) 115 985 8919
FAX: 44 (0) 115 985 7091

SPECIAL NOTE

CCT products should not be modified. Any modification may render the product unsafe and will invalidate any safety/approval marks. CCT Theatre Lighting Limited, will not accept any responsibility for any damage caused as a result of their modification.

INSTALLATION

Installation of CCT products should be carried out only by competent persons in accordance with instructions supplied with the luminaire and/or accessory. If in any doubt, consult a suitably qualified person.

LAMP FITTING

Suitable lamps - base must be GY16
220/240V 2000W CP79 CP72 CP43 or equivalent
Damaged or thermally deformed lamps **MUST NOT** be used. Lamp manufacturers instructions must be followed at all times.



Never attempt to insert a lamp with the spotlight connected to a dimmer circuit or to mains. Before opening the spotlight unplug the power cable. Failure to observe this precaution :

MAY RESULT IN SEVERE BURNS.

Do not touch the lamp surface - use the disposable glove or shield provided with the new lamp when fitting it into the lampholder. When changing a recently failed lamp, allow time for the lamp and lens to cool before removing it from the spotlight.

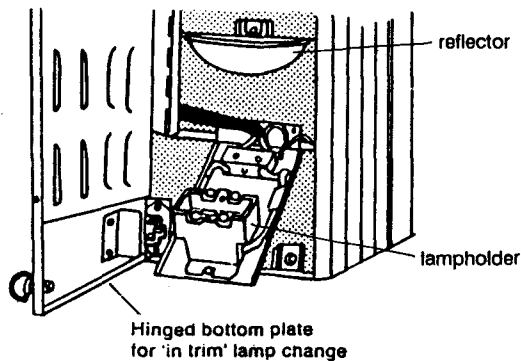
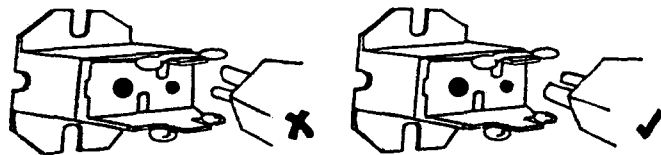

FITTING PLUG

A suitable plug of at least 10A (220/240V) rating should be fitted to the spotlight power cable, observing the connection colour code as follows:

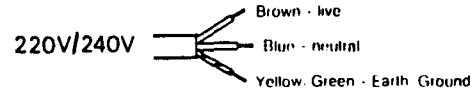

MOUNTING

WITH HOOK CLAMP

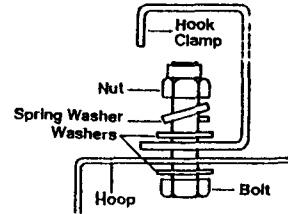

WITH SPIGOT

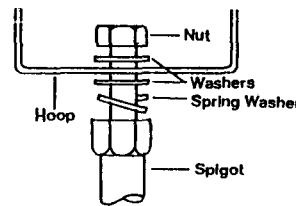

LUMINAIRE MAXIMUM SURFACE TEMPERATURE (MST)

Maximum after 5 minutes 115°C
Maximum at steady state 140°C

INSERTING COLOUR FRAME AND BARNDOOR

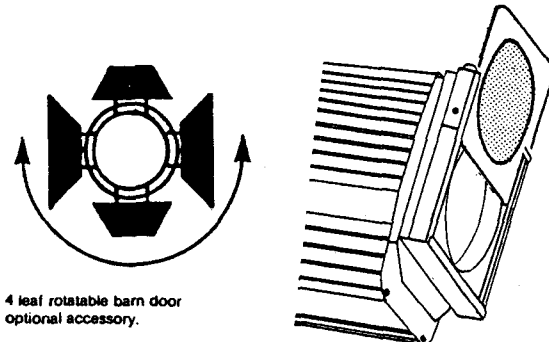

4 leaf rotatable barn door optional accessory.

BEAM SPREAD ADJUSTMENT

Beam spread control for Fresnel and Pebble Convex spotlight is achieved by moving the lamp and reflector in relation to the lens. Forward increases the beam angle and backwards reduces it. Control of the lamp and reflector is either by a control knob beneath the spotlight or a lead screw control at the rear or front

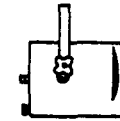

Beam Adjustment Knob

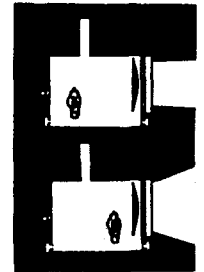
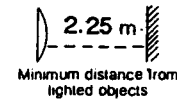

Further beam control can be achieved by using a Barndoor accessory.

FAULT FINDING

Symptom	Possible Fault	Cure
No Light	No lamp Faulty lamp No power Check circuit fuse	Fit lamp Fit new lamp Check spotlight cable Fit new fuse
Uneven light	Lamp adjustment Knob moved Lamp not fully seated in holder	Check lamp Adjustment Check lamp in lampholder observing safety precautions

MAINTENANCE

Open lamp chassis observing safety precautions. Clean the reflector through the bottom of the lamphouse using a slightly damp cloth to which a little detergent has been added. Lenses should be cleaned with a damp cloth only. Periodic inspection should be carried out, of the lampholder and cable. Any components showing wear or damage should be replaced immediately. Contact your CCT representative for list of spare parts available