



Z00DY Silhouette Profile 2500w 11-26 Deg

The Silhouette 2500w range features lamp access by a drop down hinged door allowing easy lamp change. Lamps are centred in the reflector by virtue of two adjustment screws fitted to the lamp tray. Adjustment of peak or flat is achieved by the rotation of the lead-screw which adjusts the position of the reflector relative to the lamp. Ruggedly constructed to give years of high performance trouble free service

All the lens tubes are ruggedly constructed of aluminium extrusion, steel end plates and an aluminium lid which, as the edges lock into grooves in the extruded side wall, creates a rigid octagonal box section. The lens carriers run in extruded slots supported by non metal runners which are not affected by heat. The slots are masked by an internal baffle-no light spill. All lens tube end plates carry two sets of mounting holes, the original format to allow the tube to be mounted on all Silhouette lamp houses prior to the rotatable shutter set and the new equi-distant holes which let the lens tube be mounted any way round to allow the user to "customise" his unit for the position it will be hung or stood in.

Of course the Colour Frame cassette can be rotated by undoing 4 screws to complement this facility. This cassette has two runners for colour frames or accessories like Colour Changers or DHA effects. The third slot will take an optional safety mesh which can be locked in position by bending the two tabs provided over the bottom of the mesh. For ease of lens changing the internal lens mounting plates have holes in them to allow an M5 "Nut Runner" access

Typical performance based on calibrated CP91 2500W 240V bi-plane 3200K 67,500 lumen

CCT Z00DY Silhouette Profile 2500w 11-26 Deg

Minimum angle					Maximum angle				
Peak candela (cd)	393,600				Peak candela (cd)	126,300			
Beam Angle (*)	9.5				Beam Angle (*)	27			
Cut off angle (*)	10.5				Cut off angle (*)	26			
Distance (m)	12	18	24	30	Distance (m)	12	18	24	30
Cut off dia (m)	2.16	3.24	4.32	5.40	Cut off dia (m)	5.76	8.64	11.52	14.40
Peak Illumination (Lux)	2,735	1,215	685	435	Peak Illumination (Lux)	875	390	220	140

All photometric data given is indicative of typical performance only. Specifications and materials may be changed without prior notice. Field angle where intensity drops to 10% of peak lux. Beam angle where intensity drops to 50% of peak lux. Cut off angle where intensity drops to zero of peak lux

Reference Information

Weight 19.7kg

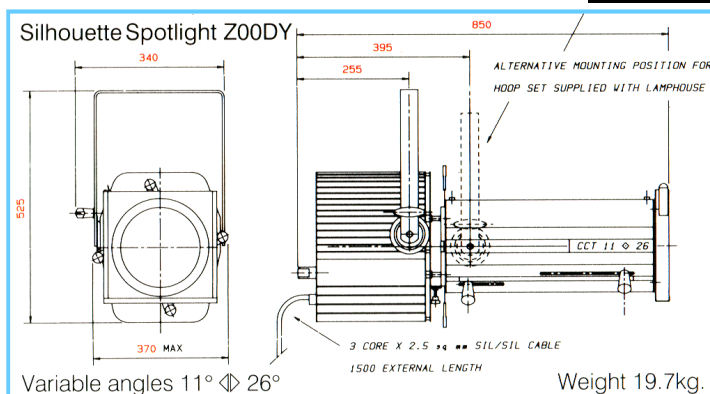

Accessories

Z0011	Colour frame
Y0025	CP 2500w lamp
Y0026	CP 2500w lamp
Z0018	Drop In iris
Z0120	Gobo Holder